

WOLTMAN WATER METER

Application

Measuring the volume of cold (hot) water passing through the pipeline.

Features

- Removable element structure, easy installation and maintenance, register for universal use within this range detachable without Removing the meter from the pipeline.
- Dry-dial, Magnetic drive sensitive action, small pressure loss.
- Vacuum sealed register ensures the dial keep free from fog and Keep the reading clear in a long term service.
- Selected high quality materials for steady & reliable characteristic.
- Technical data conform to international standard ISO 4064.

Optional Features

- Plastic register, copper register and full glass register.
- Accuracy: Class B
- Size: DN50-600mm.
- Cold / Hot water.
- Reed switch option.
- Flange standard can be choose.
- 360 degree rotate can be choose.
- Cast iron, Ductile iron, SS304,SS316 body can be choose.
- Working pressure: 10bar/16bar.
- Color can be change on body and cover.

Working Condition

- Water temperature: 0.1 °C ~ 50 °C (0.1 °C ~ 90 °C for hot water meter).
- Water pressure: 16bar /25bar.



Common Plastic Register



Copper Register



Full Glass Register

Maximum Permissible Error

- In the lower zone from Q_{min} inclusive up to but excluding Q_t is $\pm 5\%$.
- In the upper zone from Q_t inclusive up to and including Q_s is $\pm 2\%$ ($\pm 3\%$ for hot water meter).

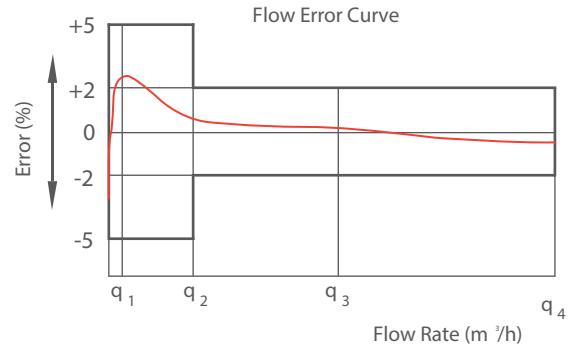

Pulse Position

Size	Pulse Position
DN50-65	10/100/1000L/Pulse
DN80-200	100/1000L/Pulse
DN250-300	1000L/Pulse



Pressure Loss Curve

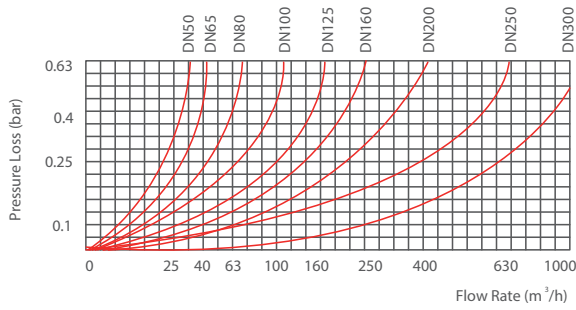

• DN50-300

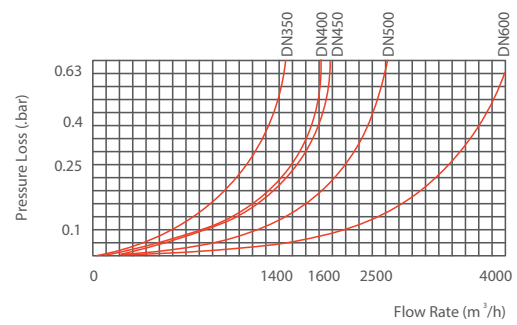

• DN350-600

Dimensions

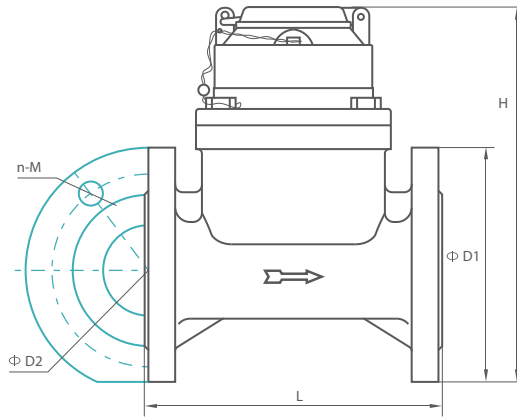

Nominal Diameter	L Length	H Height	Connecting Flange		
			ΦD1 Outside Diameter	ΦD2 Bolt Circle Diameter	Connecting Bolts (n-M)
	mm				
50	200	214	165	125	4-M16
65	200	224	185	145	4-M16
80	225	279	200	160	8-M16
100	250	289	220	180	8-M16
125	250	299	250	210	8-M16
150	300	319	285	240	8-M20
200	350	346	340	295	8-M20(10bar)
					12-M20(16bar)
250	450	434	395(10bar)	350(10bar)	12-M20(10bar)
			405(16bar)	355(16bar)	12-M24(16bar)
300	500	480	445(10bar)	400(10bar)	12-M20(10bar)
			460(16bar)	410(16bar)	12-M24(16bar)

• DN50-300

Nominal Diameter	L Length	H Height	Connecting Flange			
			ΦD1 Outside Diameter	ΦD2 Bolt Circle Diameter	Connecting Bolts(n-M)	Working Pressure (bar)
	mm					
350	500	590	505	460	16-M20	10
			520	470	16-M24	16
400	600	660	565	515	16-M24	10
			580	525	16-M27	16
450	600	700	615	565	20-M24	10
			640	585	20-M27	16
500	800	760	670	620	20-M24	10
			715	650	20-M30	16
600	800	880	780	725	20-M27	10
			840	770	20-M33	16

• DN350-600

NOTE: The flange dimension conforms to ISO7005-1 standard. Flange standard can be customized. Order for products of special requirements is also accepted.

⊗ Flow Technique Specification

Nominal Flow	Class	Overload Flow Rate (Qs)	Permanent Flow Rate (Qp)	Transitional Flow Rate (Qt)	Minimum Flow Rate (Qmin)	Minimum Reading	Maximum Reading
DN		m ³ /h				m ³	
50	B	30	15	3.0	0.45	0.0002	999,999
65	B	50	25	5	0.75	0.0002	999,999
80	B	80	40	8.0	1.2	0.002	999,999
100	B	120	60	12	1.8	0.002	999,999
125	B	200	100	20	3	0.002	999,999
150	B	300	150	30	4.5	0.002	999,999
200	B	500	250	50	7.5	0.002	999,999
250	B	800	400	80	12	0.002	999,999
300	B	1200	600	120	18	0.02	9,999,999

⊗ The Operation Description Of The Two Reed Switches System

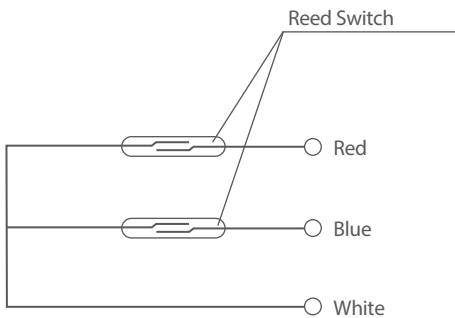

Please see the diagram of the two reed switches system below, the two reed switches would be operated "ON" OR "OFF" respectively by the magnet fitted to the pointer or gear during its running on the register, but never "ON" at the same time ,unless the out- magnet attacks.

The two reed switches operate two "ON" and two "OFF" in one round of the pointer or the gear means one signal output, this principle prevent the loss or overcounting of the signal output due to the switches joggling or the pipe vibrating, so assures reliability of the signal output.

